



Revista Internacional de Investigación e Innovación Tecnológica

Página principal: www.riit.com.mx

Dynamical Model for a Domestic Cooling Appliance by considering the Thermal Load Non-Linear Effects

Modelo Dinámico de un Refrigeración Domestico considerando los Efectos No-lineales de la Carga Térmica

Rodríguez-Vázquez E. E.

Laboratorio Nacional de Investigación en Tecnologías del Frío; Centro de Ingeniería y Desarrollo Industrial, C. P. 76130, Querétaro, Querétaro.
eedmundorv@gmail.com

Technological innovation: Modelling, control and technological system optimization of complex dynamic

Industrial application area: Development and/or improvement of comercial cooling systems.

Received: 27 January 2016.

Accepted: 30 October 2017.

Resumen

Hoy en día, las tecnologías de enfriamiento por compresión de vapor que son los dispositivos más utilizados para el acondicionamiento ambiental o la conservación de alimentos se enfrentan a un escenario tecnológicamente disruptivo, debido al rendimiento energético alcanzado por las nuevas tecnologías alternativas de enfriamiento y a su falta de sustentabilidad energética. Pero la visión de los expertos en refrigeración converge en una predicción de veinte años de diferencia entre la desaparición de la tecnología de compresión de vapor y la consolidación comercial de una nueva alternativa tecnológica, por lo que aún existe la necesidad de mejorar el rendimiento energético de la tecnología de enfriamiento por compresión de vapor. En este escenario, este trabajo propone la sintetización de un modelo de espacio de estados para un refrigerador de compresión de vapor, a partir de las ecuaciones de equilibrio de sus dos subsistemas dinámicos (térmico y eléctrico). Este modelo de espacio de estados considera un conjunto de valores de constante de tiempo para el momento inercial térmico tomando como referencia cinco niveles de carga térmica. Las constantes de tiempo térmicas se obtuvieron de un conjunto de experimentos realizados en las instalaciones de CIDESI-LaNITEF y mediante el uso de un instrumento basado en sensores MEMs desarrollado por LICORE. La predicción numérica del modelo de espacio de estados es consistente con los resultados experimentales en términos de nivel de carga térmica y la demanda de energía. Los resultados del modelo se utilizarán para desarrollar un controlador que optimice el rendimiento energético del refrigerador.

Palabras clave: Aparatos de refrigeración, carga térmica, compresores lineales, modelación dinámica.

Abstract

Nowadays vapor compression cooling technologies which are the most used devices for ambient conditioning or food preservation are facing a technological disruptive scenario, due to the energetic performance achieved by the new alternative cooling technologies and their energetic un-sustainability. But the refrigeration experts vision converges in a prediction of a twenty years gap between the disappearance of the vapor compression technology and the commercial consolidation of a new alternative technology, so the need to improve the energetic performance of the vapor compression cooling technology, still exists. In this scenario this paper proposes the synthesization of a states space model for a vapor compression refrigerator, from the equilibrium equations of its two dynamic sub-systems (thermal and electrical). This state space model considers a set of time constant values for the thermal inertial moment taking reference of five thermal load levels. The thermal time constants were obtained from a set of experiments performed at the CIDESI-LaNITeF facilities and by using a MEMs sensors based instrument developed by LICORE. The numerical prediction of the state space model are consistent with the experimental results in terms of thermal load level and the energy demand. Model results will be used to develop a controller to optimize the refrigerator energetic performance.

Keywords: Cooling appliances, dynamical model, linear compressors, thermal load.

Introduction

Society development is always proportional to the energy consumption per member. Since the industrial revolution, developed economies have been supported by the ways that they store and collect their energetic resources, from the food preservation to the complex systems developed to move oil for its commercialization, by considering also the human adaptation to the ambient conditions and the cooling of high performance machinery needed by the most lucrative activities of social communications [1, 3].

Because of the industrial and commercial background, the cooling technologies based on vapor compression are the most used to solve the social activities listed in the previous paragraph; there are many reports about the impact of these systems in the economy and in ambient contamination. For example it has been estimated that in 1997 around one billion of these systems were installed in the U.S. [4] and in 2011 more than eleven terawatts were used to energize these cooling systems [3].

In this context cooling systems based on vapor compression are facing a disruptive scenario, which has been mainly seen by two fronts: firstly the ambient preservation, if it is considered that each of these cooling systems produces an average of two tons of carbon dioxide per year [5], and second the development of new technologies for cooling purposes, which performances are close to get the same energy behavior that the vapor compression systems [6-8].

This work has been developed with the intention of improving the energy performance of the current commercial cooling appliances which are based in vapor compression systems. The dynamic model for this cooling system has been obtained from a set of experimental tests for the dynamic behavior characterization, which have been developed by considering five levels of thermal load (100%, 75%, 50%, 25%, 0%) and with the ambient temperature fixed in an ambient conditioning test chamber. The future intention is to develop an algorithm for its control and its energy

optimization once the dynamic model has been validated.

II. Materials and equipment

The cooling process by energy transportation can be defined as the one in which the temperature of a confined space (cooling chamber) is lowered by heat removal. This heat inside the volume is removed through a heat exchange process that transports it to another place outside the confined volume; being the energy transportation media in this case a refrigerant flow.

i. Cooling systems based on gas compression

Essentially a cooling system based on vapor compression is a thermodynamic system that uses a compressed fluid to transfer heat; this fluid is known as refrigerant [9, 10]. In the current commercial systems the fluorocarbons are used as the preferred refrigerants, because of their thermodynamic properties that are the most suitable for energy storage and its transportation, since their boiling points are low due to their high evaporation heat, and also because they have a moderate density in their liquid phase, but in their gas state their density is high [11].

The cooling system based in vapor compression mainly consists of: a compressor, a condenser, an expansion valve and an evaporator. The diagram of the Fig. 1 illustrates the simplest setup of these cooling systems.

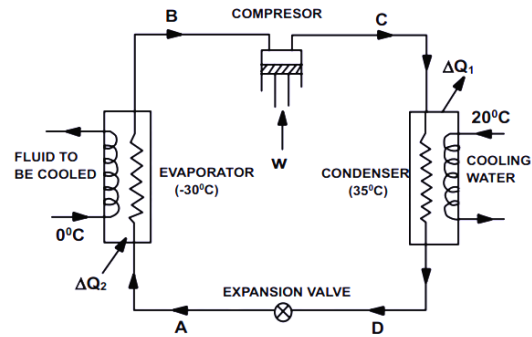

Figure 1. Schematic diagram of the current cooling systems based in vapor compression [12].

The ideal thermodynamic cycle of cooling systems based in vapor compression, as the one shown in Fig. 1, starts with the isotropic compression of the refrigerant flow that is entering to the compressor as vapor with high temperature and low pressure. The refrigerant is compressed to a high pressure and thus at a constant volume the refrigerant temperature also increases.

The refrigerant leaves the compressor with a high temperature and a high pressure, so while it flows through the condenser, the refrigerant fluid is condensed. Due to this condensation an isobaric heat transmission is performed from the refrigerant to the surrounding fluid. Then, the refrigerant leaving the condenser is liquid but it has the same high pressure with a lower temperature.

When the refrigerant passes through the expansion valve its pressure decreases and assuming a constant volume at the expansion valve then its temperature also decreases. While the refrigerant is flowing through the evaporator, it has both a low pressure and a low temperature, which is lower than the temperature of the surrounding fluid in the confined space, and again an isobaric heat transmission is performed from the confined space to the refrigerant. So the heat extraction is completed.

ii. Cooling systems modeling

The state of the art in the cooling systems modeling is mainly focused on three paradigms: thermodynamics, dynamical systems and smart algorithms. The thermodynamic models are based on the energy and mass conservation laws, so that they do not consider transient states. They are grounded on thermodynamic states of compressible gas and their static interaction through the thermodynamic cycle previously described [13, 14].

For sure, the dynamics of these systems are nonlinear, then several efforts to model its behavior with smart algorithms have been done [15-17], but these models do not have physical interpretations so the systems designers are not able to interpret their results to increase the performance of their designs.

In the case of dynamical systems, the most complete methodology is based on the thermodynamic relationships of its variables but their dynamical momentums are also considered, then their models have a big set of state variables which are related with nonlinear equations [18].

iii. Dynamical model for cooling systems

All these models are too complex to be implemented for the tuning of a control algorithm into the hardware of the current commercial cooling appliances, so the proposal of this work is to get a mathematical model based in linear dynamical systems simplified for its industrial implementation in the current technologies of cooling systems based on vapor compression with linear compressors.

The dynamical model is grounded in the next set of considerations:

1.- The thermal behavior of the confined volume into the cooling chamber is as slow as it needs to be to despise the airflow turbulence which can affect the spatial distribution of the temperature inside, then this temperature can be considered homogeneously into the entire confined volume.

2.- The heat transfer between the refrigerant and confined volume is performed all along the evaporator heat exchanger, so the heat source (for extraction) is considered punctual and it affects homogeneously the confined volume temperature.

3.- In the same way the refrigerant temperature along the evaporator is considered homogeneous once the heat has been transferred.

With this statement the mathematical model of the cooling appliance based in vapor compression has been expressed with a set of linear equations which define the dynamical system as:

Thermal energy dynamics into the cooling chamber

$$Q(t) = C \frac{d}{dt} T_i(t) + R_1 \{T_i(t) - T_a(t)\}, \quad (\text{Eq. 1})$$

Thermal energy interchange into the evaporator device

$$Q(t) = R_2 \{T_c(t) - T_i(t)\} + K_1 q(t), \quad (\text{Eq. 2})$$

Thermal energy transportation capacity of the coolant

$$q(t) = K_2 \omega(t), \text{ and } \quad (\text{Eq. 3})$$

Mechanical energy into the compressor device

$$F(t) = K_3 \omega(t) + K_4 \frac{d}{dt} \omega(t), \quad (\text{Eq. 4})$$

where:

$Q(t)$ Heat removed from the thermal load at the confined volume,

$T_i(t)$	Temperature inside the confined volume,
$T_a(t)$	Ambient temperature,
C	Thermal capacitance of the confined volume component,
R_1	Thermal resistance of the wall that confines the volume of the cooling chamber,
$T_c(t)$	Homogeneous temperature of the refrigerant at the evaporator,
$q(t)$	Refrigerant mass flow through the evaporator heat exchanger,
R_2	Thermal resistance of the refrigerant pipeline along the evaporator geometry,
K_1	Thermal constant of the relationship between heat extraction and refrigerant flow,
$\omega(t)$	Angular speed of the compressor motor,
K_2	Constant for the relationship between refrigerant flow and compressor speed,
$F(t)$	Frequency set point to realize an angular speed at the compressor motor,
K_3	Constant for the relationship between compressor speed and frequency set point, and

K_4 Constant for the relationship between compressor acceleration and frequency.

Equation 1 describes the dynamic of the heat transfer between the confined volume and the evaporator surface inside the cooling chamber, while equation 2 defines this heat transfer between the evaporator surface and the refrigerant flowing inside the evaporator pipeline. Equations 3 and 4 describe the dynamic relationship between the refrigerant flow, the compressor motor speed and the frequency set point for the motor driver to achieve the speed requested.

This mathematical model has been synthesized to study the linear dynamics between the most important variables which are measured and considered in current commercial cooling appliances, taking the frequency set point for the driver of the compressor motor as the only degree of freedom to modify the internal temperature of the cooling chamber and considering the thermal and dynamic coefficients that can be modified by the industrial designers. Then the linear space state of this model can be represented as:

$$\begin{bmatrix} \frac{d}{dt} T_i(t) \\ \frac{d}{dt} \omega(t) \end{bmatrix} = \begin{bmatrix} -\frac{R_1 + R_2}{C} & \frac{K_1 K_2}{C} \\ 0 & -\frac{K_3}{K_4} \end{bmatrix} \begin{bmatrix} T_i(t) \\ \omega(t) \end{bmatrix} + \begin{bmatrix} \frac{R_2}{C} & \frac{R_1}{C} & 0 \\ 0 & 0 & \frac{1}{K_4} \end{bmatrix} \begin{bmatrix} T_c(t) \\ T_a(t) \\ F(t) \end{bmatrix} \quad (\text{Eq 5})$$

$$\begin{bmatrix} y_1(t) \\ y_2(t) \end{bmatrix} = \begin{bmatrix} T_i(t) \\ \omega(t) \end{bmatrix}$$

The matrices coefficients would be constants if the model were entirely linear, but in this case to get a better approximation, these set of parameters have been defined for the five levels of thermal load percentage; so the main hypothesis of this model is that the nonlinearity of this cooling phenomena can be a thermal load function.

It is important to highlight that the electrical and mechanical dynamics of this model are

much faster than the thermal dynamics, so the electro mechanical time constant is bigger than the thermal one, but to know their magnitude a set of experiment was developed.

Experimental methods

In this work, the experimental setup consisted in a modified refrigerator, which dynamics behavior of the internal

temperature was monitored through two instrumental systems. Table 1 lists the refrigerator and the instrumentation systems

technical characteristics, as well as the experimental testing variables magnitudes.

Table 1. Technical data of the experimental cooling system.

Refrigerator Characteristics		Experimental testing variables	
Refrigerant	RC14 mixture	Ambient Temperature	24 °C
Capacity	0.75 m ³	Refrigerant Temp.	4.4 °C (in chamber)
Linear Compressor Systems		Instrumentation 1	NI – CompacDAQ
Compressor Power	1.8 KW		Thermocouples
Controller	Spartan III (FPGA)	Instrumentation 2	LICORE ICE Bug
			MEMs Sensors

The instrumental systems were controlled through a virtual instrument, which acquires the sensors signals and control the variables activation with a FPGA controller. Fig. 2 shows both the external hardware of the virtual instrument and the cooling chamber of the concerned refrigerator.



Figure 2. Experimental setup for the refrigerator characterization testing.

The experimental validation of the proposed model (5) was focused on obtaining the time constants for each electromechanical and thermal subsystems, and as well as mentioned, these constants were obtained from the dynamical response of the cooling appliance while working with five levels of thermal load.

The characterization testing procedure was developed in an ambient conditioning chamber available at LaNITeF (Mexican Laboratory for Cooling Technologies Research). Taking in advantage the

instrumentation systems in this laboratory, the refrigerant temperature was also measured to confirm that its average value along the evaporator geometry had a constant behavior and that it was close to its boiling point. Meanwhile the compressor motor speed was also set in 32 rpms and as well as shown in Fig. 2 the compressor dynamics just had two options with or without thermal load.

In the Figs. 3 and 4 the dynamical behaviors of each subsystem obtained experimentally are shown, where the transient response is illustrated while the entire system starts to work to achieve the refrigerant temperature inside its cooling chamber.

Fig. 3 shows that the inertia moment of the electromechanical subsystem of the refrigerator does not change with relation to the thermal load level, it does only in the case that this load is absent. On the other hand, the thermal load level strongly affects the thermal time constant, as illustrated on Fig. 4.

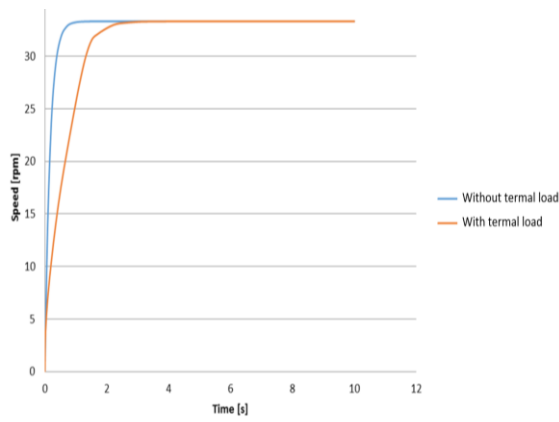

Figure 3. Experimental response of the electromechanical subsystem (with and without thermal load).

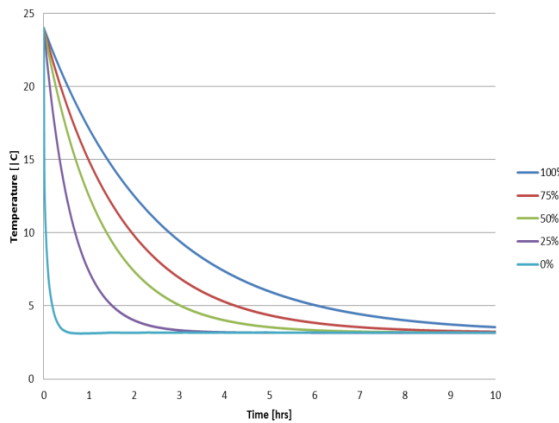

Figure 4. Experimental response of the thermal subsystem (for the five levels of thermal load percentage).

Model predictions results

In terms of the theoretical proposal to get the mathematical model for the dynamic behavior of a cooling appliance by considering the thermal load effects, simulation results of the proposed model (5) considering the same scenarios of the experimental testing are shown in Fig. 5. These internal temperature behaviors for the different levels of thermal load, were obtained by applying the set of time constant values calculated from the experimental results and listed on Table 2.

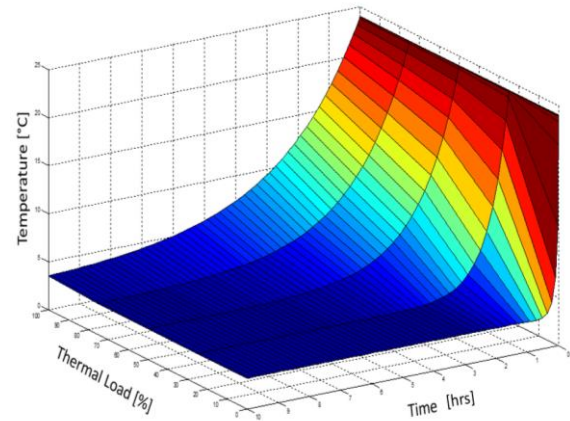

Figure 5. Model simulation results.

Table 2. Calculated values of the time constants from the experimental results.

Load level	Electromechanical time constant $\approx \frac{K_3}{K_4}$	Thermal time constant $\approx \frac{R_1 + R_2}{C}$
0 %	-42	-0.50
25 %	-69	-0.62
50 %		-0.68
75 %		-0.71
100 %		-0.73

Results discussions

Based on table 3 and Fig. 6 results, it can be said that model simulations have almost the same dynamical behavior than the cooling appliance tested, and their thermal responses

are coherent with the ones reported previously by authors in two postgraduate thesis [19, 20]. So that, with this validation of the cooling appliance model which considers the non-linear effect of the thermal load in the dynamic behavior of the internal

temperature, it can be applied to synthesize a control algorithm to accurately compensate

the thermal inertial moment and get an optimized performance in future works.

Table 3. Model simulation errors respect to the experimental values.

Load level	Experimental Results		Rodriguez Model [19]		Dominguez Model [20]	
	Average error at steady state	Peak error at transient state	Average error at steady state	Peak error at transient state	Average error at steady state	Peak error at transient state
0%	5.2 %	4.3 °C	6.7 %	Does not reported	8.0 %	5.4 °C
25%	4.5 %	3.6 °C	5.8 %			
50%	3.0 %	2.2 °C	5.0 %			
75%	4.3 %	3.2 °C	6.1 %			
100%	5.0 %	3.8 °C	7.2 %			

Differences between electromechanical and thermal time response magnitudes are consistent with at least their magnitude orders. Also the negative signs indicate that this is a stable system as the one that was experimentally characterized here.

The non-constant geometry of the surface response from the internal temperature shown in Figs. 4 and 5, highlights the non-linear behavior of this cooling appliance, therefore with these results it can be said that this non-linearity depends on the model (5) coefficients, which look more like a function of the thermal load.

Conclusions

The main hypothesis that considers the time responses as a function of the thermal load has been verified, by getting a considerable accurate (see table 3) dynamical model for the cooling system.

By considering the experimental validation of the non-linear model for this cooling appliance based in vapor compression exposed here, the designers can modify their designs based on the time responses to increase the energetic performance of these cooling appliances. Also control engineers have the ability to synthesize and tune control algorithms with the intention of optimizing the energy performance.

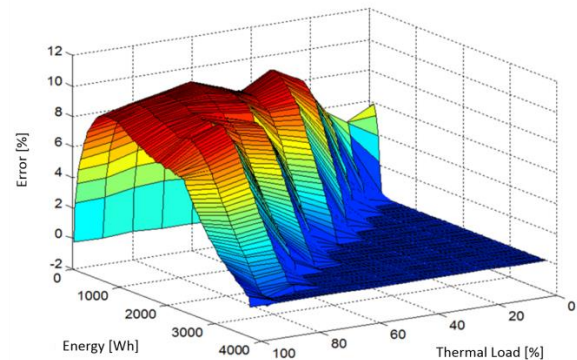

Figure 5. Model vs experimental measurements.

Acknowledgement

The author is grateful to CONACYT for the doctoral scholarship, also to ITQ, CIDESI-LaNITeF LICORE and AICA for their support and facilities to develop this work. Acknowledgments are extended to the work team mainly to Dr. José C. Pineda, Dr. Hugo Games, M.I. Guillermo Dominguez, Ing. Jorge L. Iglesias, Ing. Keops X. Garcia, Ing. H. Pérez and the Rodriguez family.

Reference

1. Koomey J.G., 2007. Estimating total power consumption by servers in the U.S. and the world, Boston U.S., Stanford University.
2. PB, 2012. Statistical review of the world energy. www.bp.com/statisticalreview, U.S., bp Global.
3. U.S. Energy information administration, 2012. Electric power monthly. Washington U.S.

4. U.S. Energy information administration, 1997. A look at residential energy consumption in 1997. Washington U.S.
5. Steeland K. Fletcher T. and Savits D., 2011. Epidemiologic evidence on the health effect of perfluorooctanoic acid. *Environmental health perspectives*, Vol. 18, No. 8.
6. Russel D. A., Weigull P., 2002. Tabletop thermoacoustic refrigerator for demonstrations. *American Journal of Physics*. December 2002. pp. 1231–1223, American association of physics teachers.
7. Monen A. M., 2014, *Magnetocaloric Refrigerator Freezer*, U. S. Department of Energy.
8. Dongzhi G., Jinsheng G., Ying-Ju Y., Suresh S., Slippey A., Fedder G. K. McGaughey A. J. H. and Yao S., 2014. Design and modeling of a fluid-based micro-scale electrocaloric refrigeration system, *International Journal of Heat and Mass Transfer*, No. 72 pp. 559–564, Elsevier.
9. Rao Y. V., 2003. *An introduction to thermodynamics*, Ed. University Press.
10. Eurostat, 2012. Final electricity consumption. <http://ec.europa.eu/eurostart/>, Eurostart.
11. Sundarajan T. and Malikaarjuna J., *Refrigerant Cycles*, Indian Institute of Technology Madras.
12. Bennett C. and Myers J., 1975, *Momentum, heat and mass transfer*, Ed. Tara McGraw Hill.
13. Gibbs J. W., 1873. Graphical methods in thermodynamics of fluids, *Transactions of the Connecticut Academy of Arts and Science*. Connecticut U.S.
14. Chang W. R., Liu D. Y. Chen S. G. and Wu N. Y., 2004. The components and control methods for implementation of inverter-controlled refrigerators/freezer, Purdue University.
15. Aydinalp M. V., Ugursal I. and Fung A. S., 2002, Modeling of the appliance, lighting and space-cooling energy consumption in the residential sector using neural networks, *Applied Energy*, Vol 71, No. 2, Elsevier.
16. Knezic M., 1993. Fuzzy logic apparatus control, U.S. patent, No. 5,261,247.
17. Mraz M., 2001. The design of intelligent control of a kitchen refrigerator, *Mathematic and Computing in Simulation*, Vol. 56, No. 3, Elsevier.
18. Pineda J. C., 2012, Informe técnico del proyecto VENDO: fase de diseño conceptual, Santiago de Querétaro México, CIATEQ A. C.
19. Rodríguez E. E., 2014, Modelación y control de enfriadores comerciales como sistemas dinámicos conmutados, Santiago de Querétaro México, CIATEQ A. C.
20. Dominguez G., 2015, Diseño de una cámara fría para almacenamiento y conservación de fruta por medio de radiación solar, Santiago de Querétaro México, IT-Querétaro.